



Cambridge International AS & A Level

DESIGN & TECHNOLOGY

9705/13

Paper 1

October/November 2021

3 hours



You must answer on the answer booklet/paper.

You will need: Answer booklet/A4 paper Coloured pencils
A3 drawing paper (2 sheets) Extra sheets of A3 drawing paper if needed
A range of design drawing equipment

INSTRUCTIONS

- Answer **three** questions in total:
 - Section A: answer **one** question on the answer booklet/A4 paper provided.
 - Section B: answer **one** question on the answer booklet/A4 paper provided.
 - Section C: answer **one** question on A3 drawing paper. Use both sides of the paper.
- You may request additional sheets of A3 drawing paper, but only if you have used up both sides of each of the 2 sheets provided.
- If you have been given an answer booklet, follow the instructions on the front cover of the answer booklet.
- Use a black or dark blue pen.
- Write your name, centre number and candidate number on all the work you hand in.
- Do **not** use an erasable pen or correction fluid.
- You may use an HB pencil, or coloured pencils as appropriate, for any diagrams, graphs or rough working.
- At the end of the examination, fasten all your work together. Do **not** use staples, paper clips or glue.

INFORMATION

- The total mark for this paper is 120.
- The number of marks for each question or part question is shown in brackets [].
- All dimensions are in millimetres.

This document has **12** pages. Any blank pages are indicated.

Section A

Answer **one** question from this section on the Answer Booklet/A4 paper provided.

- 1 Fig. 1.1 shows details of the cardboard lid, box and insert used to package fragile ceramic balls. The packaging will be made in a school workshop.

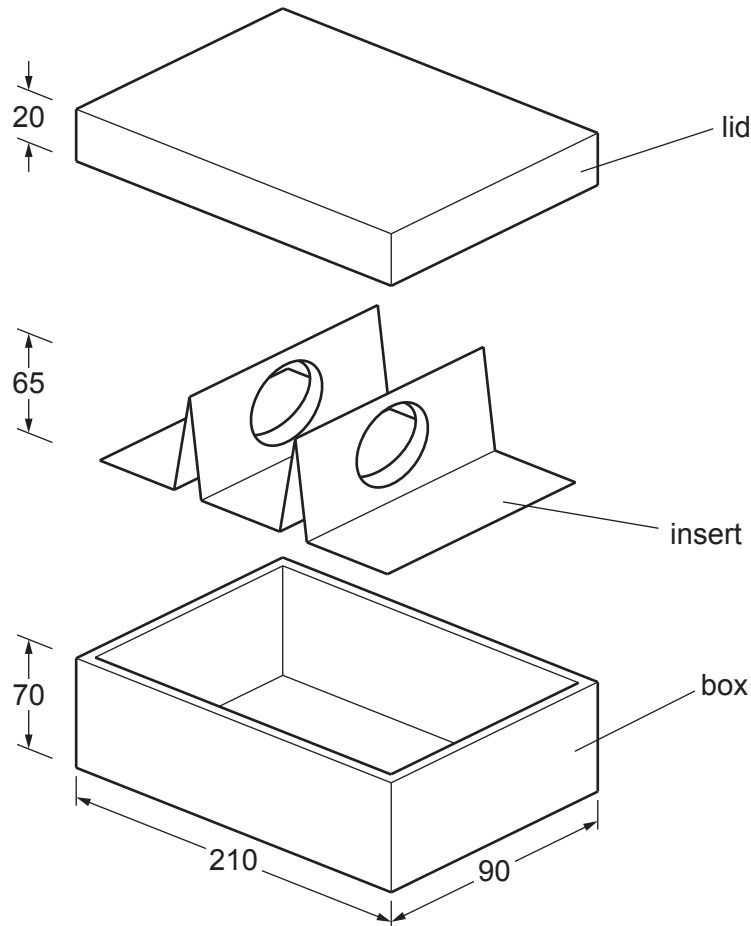

Fig. 1.1

- (a) State a suitable sheet material (other than cardboard) that could be used to make the lid and give **one** reason for your choice. [2]
- (b) Use notes and sketches to describe:
- (i) how the cardboard lid would be marked out, cut out and assembled [6]
 - (ii) how a thin plastic template could be made and used to mark out the development (net) for the insert. [6]

You must give details about the tools, equipment and processes involved and the safety precautions that have to be undertaken at each stage.

- (c) Draw the development (net), including the fold lines, required to make the box. The walls of the box are double thickness for added strength. [6]

- 2 Fig. 2.1 gives details of a wooden desk tidy that is commonly used in an office or school. The desk tidy is to be made in a school workshop.

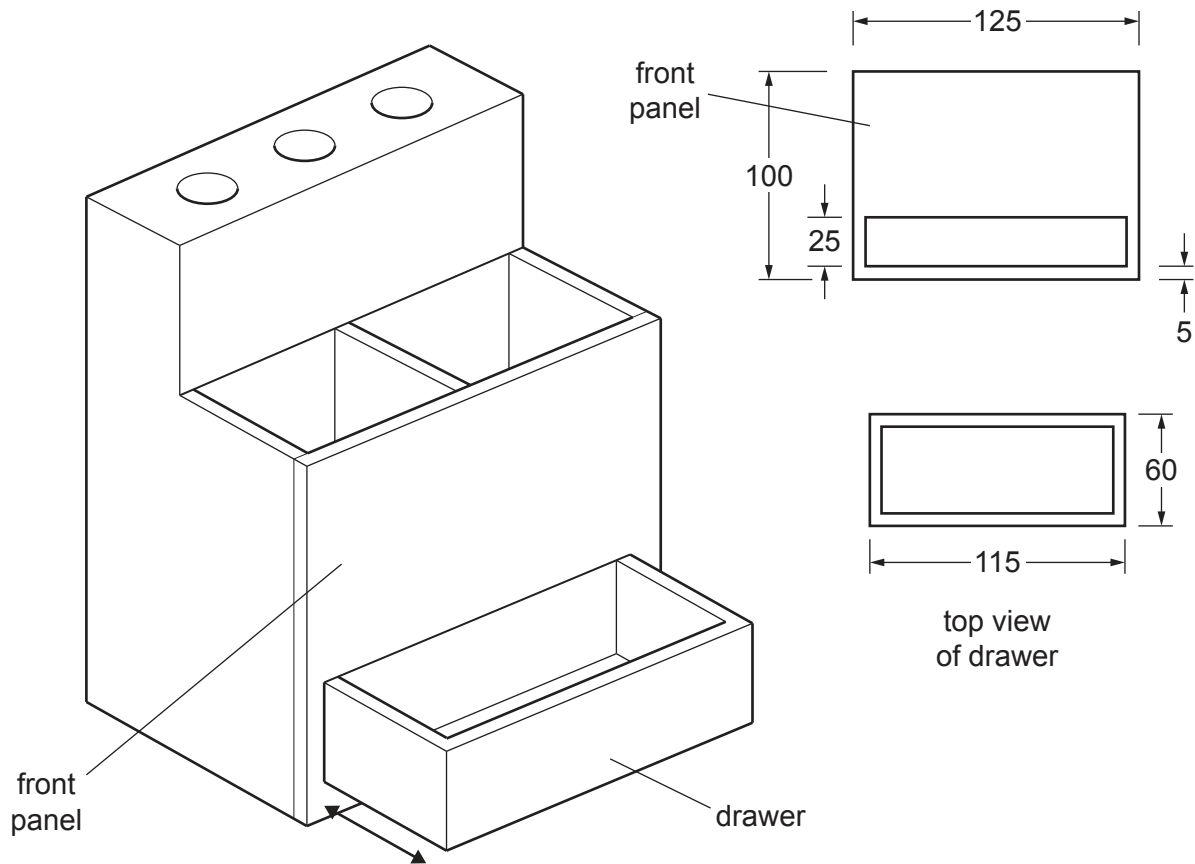

Fig. 2.1

- (a) State **two** types of wood suitable for the desk tidy. The thickness of the wood is 5 mm. [2]
- (b) Use notes and sketches to describe:
- (i) how the front panel could be made [6]
 - (ii) how the drawer could be made. [6]

You must give details about the tools, equipment and processes involved and the safety precautions that have to be undertaken at each stage.

- (c) Explain why products such as the drawer are made from flat sheet materials. [6]

- 3 Fig. 3.1 shows the blade of a sliding bevel that is to be made in a school workshop. The blade will be made from 3 mm mild steel.

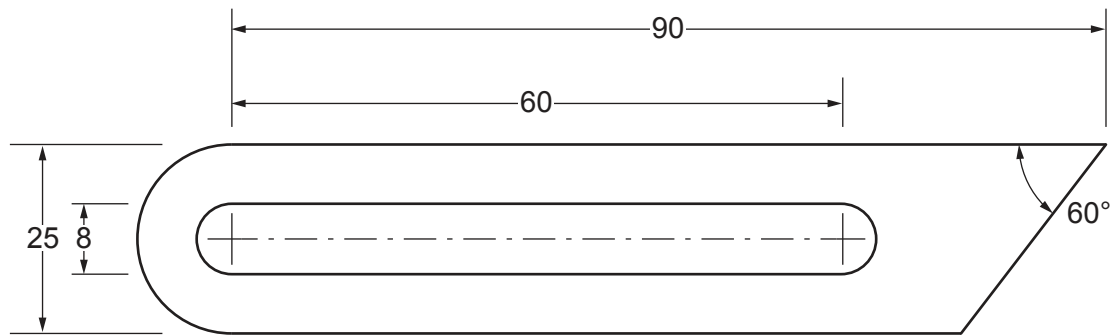

Fig. 3.1

- (a) State **two** reasons why mild steel could be used to make the blade. [2]
- (b) Use notes and sketches to describe:
- (i) how the slot could be marked out and cut out [6]
 - (ii) how the outer shape could be marked out, cut out and finished [6]
 - (iii) how the blade would be case hardened. [6]

You must give details about the tools, equipment and processes involved and the safety precautions that have to be undertaken at each stage.

Section B

Answer **one** question from this section on the Answer Booklet/A4 paper provided.

- 4 Fig. 4.1 shows a prototype cycle storage shed that is to be used at a school. The roof is manufactured from recycled plastic and the sides from reclaimed timber.

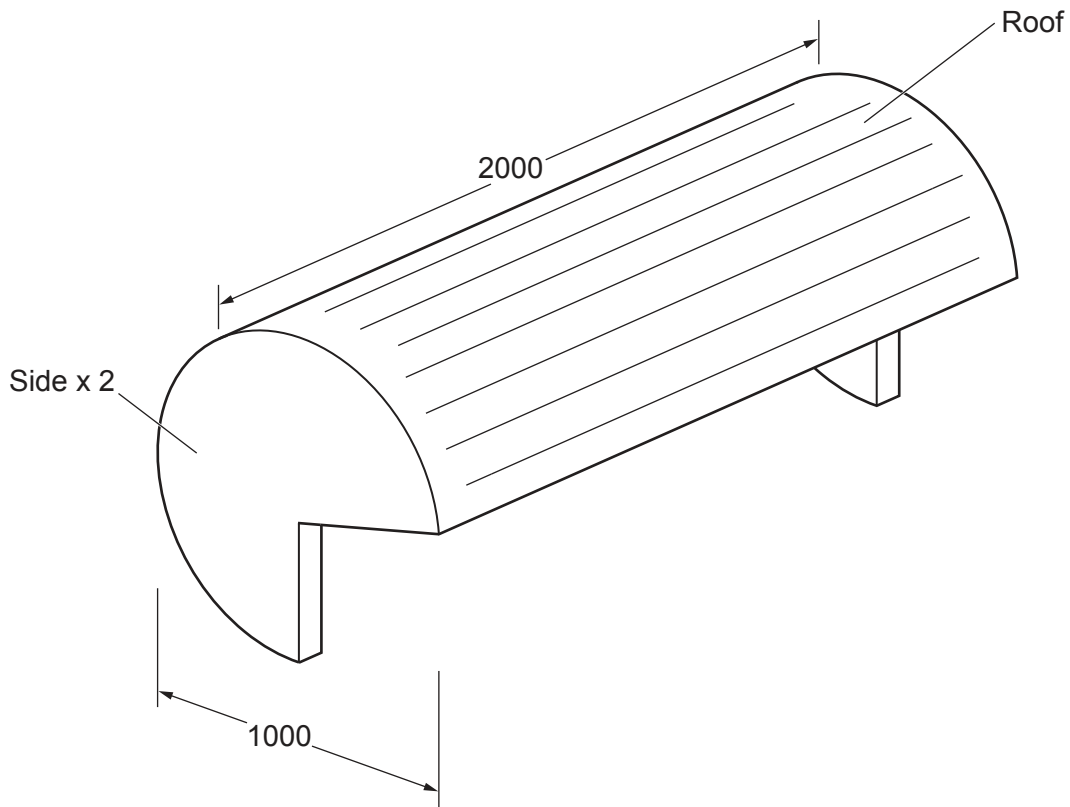

Fig. 4.1

- (a) Give **two** reasons why the roof is curved. [2]
- (b) Identify and describe **two** problems with the design of the prototype cycle storage shed. [4]
- (c) Use notes and sketches to explain how the design would need to be changed to overcome the **two** problems you have identified in **part (b)**. [6]
- (d) Discuss the importance of trialling and testing prototypes such as the cycle storage shed before batch production begins.

Your answer should:

- (i) analyse the given situation and identify **three** relevant issues raised by the question [3]
- (ii) explain why you consider these issues to be relevant [3]
- (iii) contain specific examples/evidence to support your conclusions. [2]

- 5 Fig. 5.1 gives details of a cardboard laptop stand that gives those using it a more comfortable typing position.

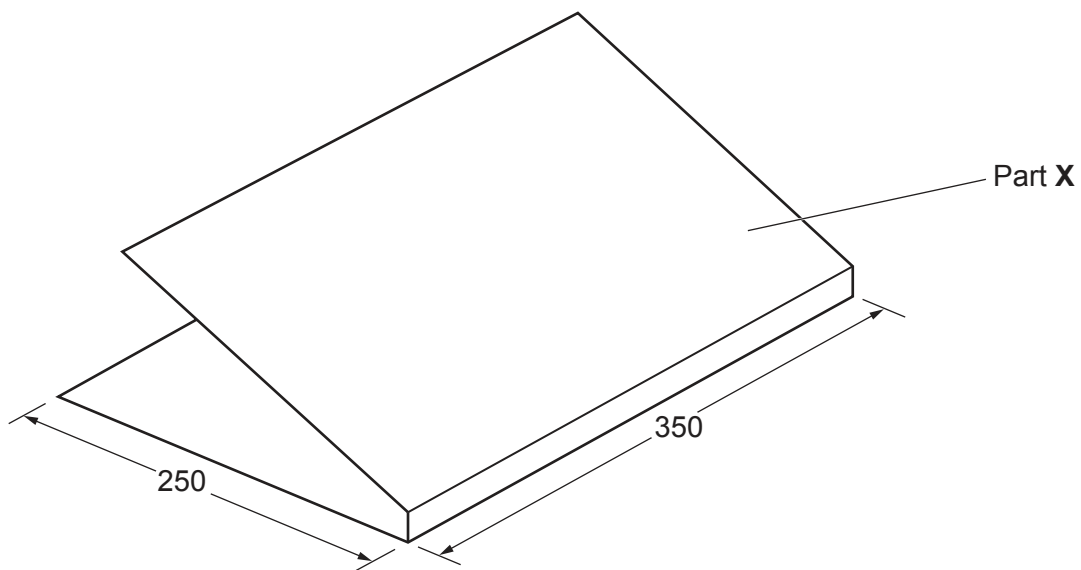

Fig. 5.1

- (a) Explain the function of Part X. [2]
- (b) Identify and describe **two** problems with the design of the cardboard laptop stand. [4]
- (c) Use notes and sketches to explain how the design would need to be changed to overcome the **two** problems you have identified in **part (b)**. [6]
- (d) Discuss the benefits of using recycled cardboard to manufacture products such as the laptop stand.

Your answer should:

- (i) analyse the given situation and identify **three** relevant issues raised by the question [3]
- (ii) explain why you consider these issues to be relevant [3]
- (iii) contain specific examples/evidence to support your conclusions. [2]

6 Fig. 6.1 shows a centre lathe that can be found in a school workshop.

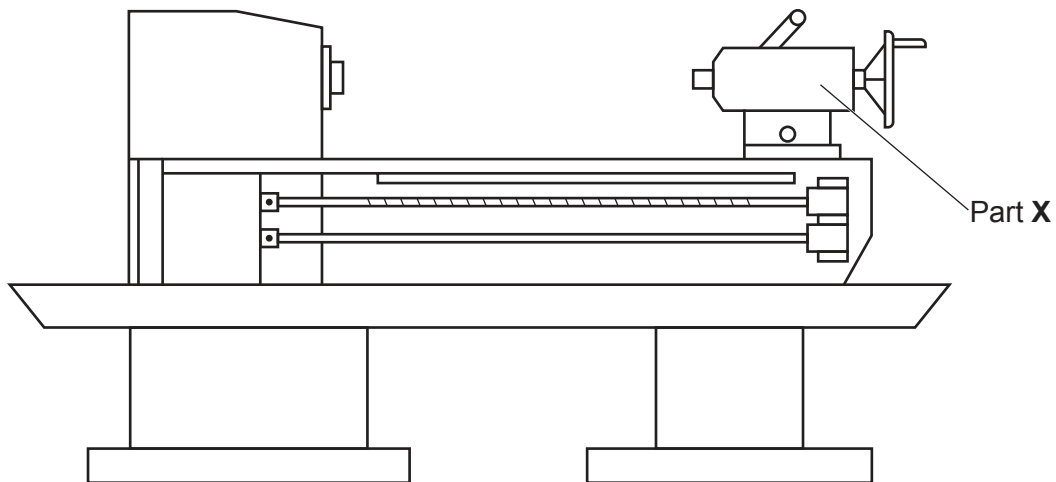

Fig. 6.1

- (a) Explain the function of Part X. [2]
- (b) Identify and describe **two** problems with the design of this centre lathe that make it difficult to use. [4]
- (c) Use notes and sketches to explain how the design would need to be changed to overcome the **two** problems you have identified in **part (b)**. [6]
- (d) Discuss why machines such as the centre lathe can run at a range of speeds between 40 rpm and 3000 rpm.

Your answer should:

- (i) analyse the given situation and identify **three** relevant issues raised by the question [3]
- (ii) explain why you consider these issues to be relevant [3]
- (iii) contain specific examples/evidence to support your conclusions. [2]

Section C

Answer **one** question from this section on the plain A3 paper provided.

You are provided with two sheets of plain A3 paper. You should use **both** sides of the paper. **Each** of the four parts (a) – (d) of the question you choose to answer should take up one side of paper.

When you are asked to **develop** a design you must show, using notes and sketches, the development and evaluation of a **range** of ideas into a single solution. The design proposal should be annotated to give details about materials, joining methods and important sizes.

7 Fig. 7.1 shows an incomplete idea for an indoor clothes airer.

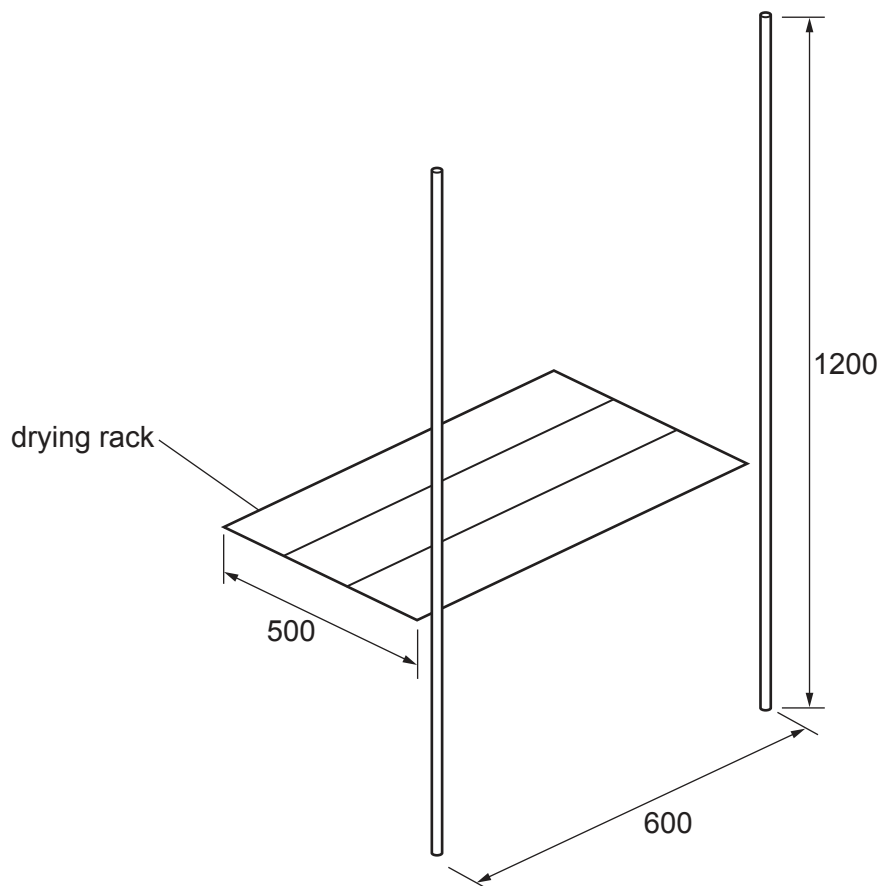

Fig. 7.1

- (a) Use notes and sketches to **develop** a design for the clothes airer. The design must allow four drying racks to be used at the same time and fold flat for storage. [20]
- (b) Use notes and sketches to **develop** a design for a base that provides stability. The base should fold flat for storage. [20]
- (c) Use notes and sketches to **develop** a design for a detachable container for clothes pegs that can be easily attached to and removed from the clothes airer. [20]
- (d) Produce a pictorial (3D) rendered drawing of the complete clothes airer which shows all the features that you have designed in **parts (a) – (c)**. [20]

8 Fig. 8.1 shows an incomplete idea for a trolley that is used for moving straw bales on a small farm.

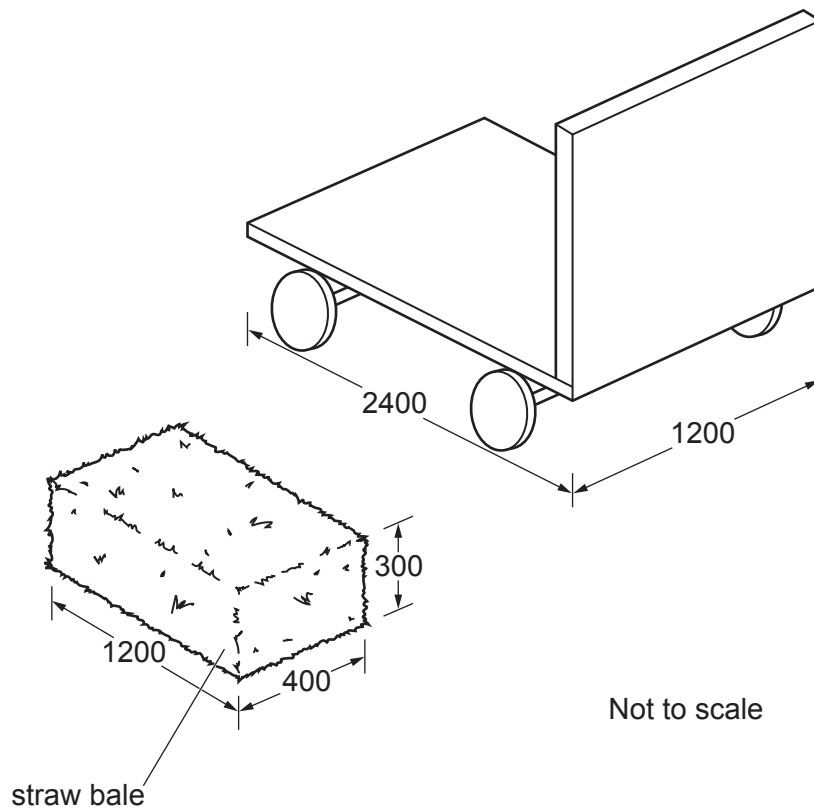

Fig. 8.1

- (a) Use notes and sketches to **develop** a design for pulling or pushing the trolley by hand. The design must include a method of steering the trolley. [20]
- (b) Use notes and sketches to **develop** a design to stop the straw bales from falling off the sides and end of the trolley. The design must allow the trolley to carry twelve bales of straw. [20]
- (c) Use notes and sketches to **develop** a design for a canopy to protect the straw bales from the weather. It must be possible to remove the canopy for ease of storage. [20]
- (d) Produce a pictorial (3D) rendered drawing of the complete trolley which shows all the features that you have designed in **parts (a) – (c)**. [20]

- 9 Fig. 9.1 shows an incomplete idea for a cardboard box to package a child's globe. The box protects and markets the product.

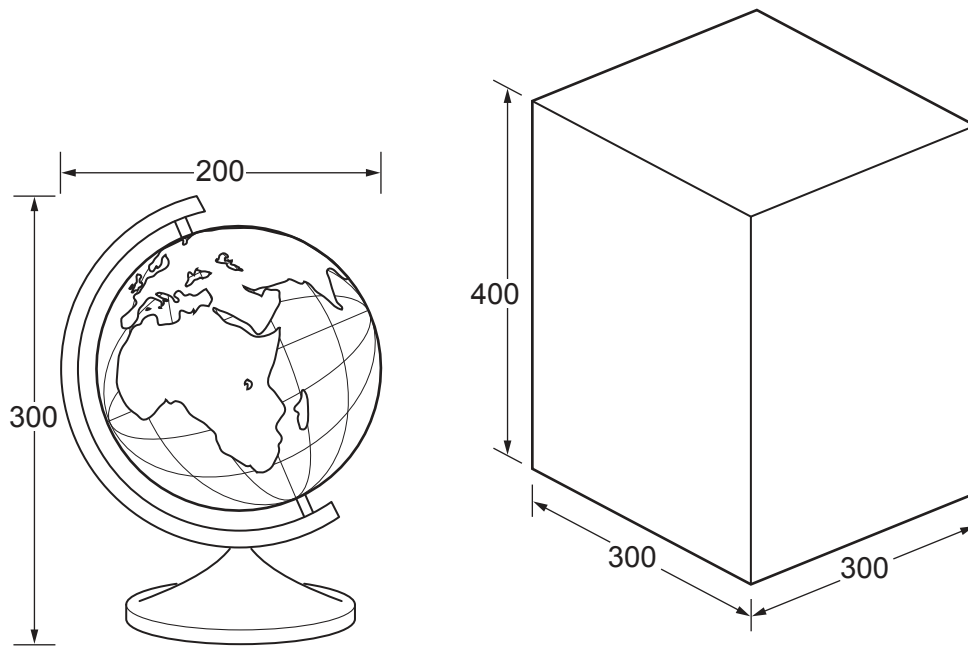

Fig. 9.1

- (a) Use notes and sketches to **develop** a design for the cardboard box. The box must be made from a one piece development (net) and have a viewing window in order to see the globe. It must be possible to open and securely close the box. [20]
- (b) Use notes and sketches to **develop** a design for the lettering and detailed graphics on the box. The name of the globe is 'The Whole World' and the lettering should be in a style that reflects the product. [20]
- (c) Use notes and sketches to **develop** a design for an insert that will prevent the globe from moving around inside the cardboard box. [20]
- (d) Produce an exploded pictorial (3D) rendered drawing of the complete cardboard box and insert with all the features that you have designed in **parts (a) – (c)**. [20]

BLANK PAGE

Permission to reproduce items where third-party owned material protected by copyright is included has been sought and cleared where possible. Every reasonable effort has been made by the publisher (UCLES) to trace copyright holders, but if any items requiring clearance have unwittingly been included, the publisher will be pleased to make amends at the earliest possible opportunity.

To avoid the issue of disclosure of answer-related information to candidates, all copyright acknowledgements are reproduced online in the Cambridge Assessment International Education Copyright Acknowledgements Booklet. This is produced for each series of examinations and is freely available to download at www.cambridgeinternational.org after the live examination series.

Cambridge Assessment International Education is part of the Cambridge Assessment Group. Cambridge Assessment is the brand name of the University of Cambridge Local Examinations Syndicate (UCLES), which itself is a department of the University of Cambridge.